

LV JUICE

LEDMAHA-PLUS

SPORTS LIGHTING



- Unrivalled efficacy 140lm/W to 150lm/W
- Asymmetric design for reduced glare, spill and with minimal wind load area
- Cost efficient 1 for 1 replacement of HID floodlights
- Excellent light distribution
- IP66, 20kV surge protection
- >80,000hrs (L80B10) at Ta 25°C
- Options on remote drivers and in wired or wireless controls



LEDMAHA-PLUS-1000

VIEW
THE RANGE



GigaTera[®]
beyond light

The ECOlight area & sports lighting range comes from GigaTera – world leaders in televised (UHD) LED sports lighting. These lights are constructed from quality materials and made to adhere to the highest quality requirements.



This Month

INDEPENDENTLY TESTED
METALWARE PAGE 2

METREL MULTIMETER &
CLAMP COMBO DEAL PAGE 7

VEHICLE SAFETY
PRODUCTS PAGE 8

FREE CRAVE FOOD ENERGY BALLS

WHILE STOCKS LAST

When you spend
over \$300 (+GST)
on one invoice
this month



TURNBUCKLES

STAINLESS STEEL

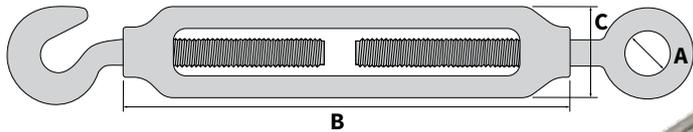

PRICED FROM
\$6.63 +GST

CAT NO.	THREAD Ø	MATERIAL	EYE I/D A (MM)	BUCKLE LENGTH B (MM)	BUCKLE WIDTH C (MM)	PACK SIZE
TNTB5	M5	304 STAINLESS	9	71	15	10
TNTB6	M6		11	92	18	10
TNTB8	M8		15	121	21	10
TNTB10	M10		16	150	23	10

D SHACKLES

STAINLESS STEEL

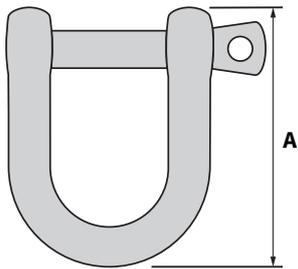

CAT NO.	PIN Ø	MATERIAL	LENGTH A (MM)	LOAD RATING (KN)	PACK SIZE
TNDSHK4	4	316 STAINLESS	28	10	10
TNDSHK5	5		34	14	10
TNDSHK6	6		38	20	10
TNDSHK8	8		48	42	10
TNDSHK10	10		65	70	10

PRICED FROM
\$2.45 +GST



CATENARY WIRE



BUY FOUR ROLLS OF THE SAME COLOUR FOR

\$25.00 + GST PER ROLL

On one invoice this month while stocks last

TransNet catenary wire has been chosen for its high tensile strength, and is manufactured and tested to AS/NZ building standards. Available in three colours (breaking strengths) - Black, Red & Green.

- 5kg coil

TEST REPORT



CAT NO.	MATERIAL	BREAKING STRAIN (KG)	COLOUR	PACK SIZE (M)
TNCAT2.6	ZINC COATED	90	GREEN	190
TNCAT3.2BK		180	BLACK	100

INDEPENDENTLY TESTED IN NZ

Each of our metalware products has been independently batch tested in New Zealand by skilled technicians to ensure that the highest quality standards are maintained. Our comprehensive metalware range is designed to perform successfully in our local environment. Robust, precise, and dependable, TransNet metalware works whenever and wherever you need it.



RANGE INCLUDES

CATENARY WIRE • WIRE STRAINER RATCHETS • DOGBONES • MOUNTING HARDWARE • JACK CHAIN • GIRDER SPRING SADDLES • FULL SADDLES • HALF SADDLES • STAINLESS STEEL D SHACKLES • STAINLESS STEEL WIRE GRIPS • REDUCERS • TURNBUCKLES • ZINC PLATED NUTS • ZINC PLATED WASHERS • THREADED ROD • TROFFER SUPPORT CLIPS • SPLIT BOLT CONNECTORS • INTUMESCENT FIREPADS

TRANSNET MONTHLY GIVEAWAY SUPPORTING KIWI BUSINESSES

We really enjoy exploring local businesses and discovering the awesome things being made here in New Zealand by talented Kiwis, and we hope you catch some of our enthusiasm when you receive our monthly giveaway. This February we want you to

try another tasty snack from The Herb and Spice Mill. You enjoyed their savoury dip sachets over the holiday period and this time we wanted to treat our customers to something sweet, so what

www.herbandspicemill.co.nz

could be better than a pack of their delicious locally manufactured sweet coconut cashew & cacao energy balls?



All Specials and Products featured in TRANSNET JUICE are available from all good electrical wholesalers.





GURO BRANCH JOINTS FOR XLPE UP TO 1KV

Designed for use with LV cables, these joint kits consist of an impact resistant, transparent polypropylene snap-to-close designed housing, polymer foam for sealing, GUROFLEX environmentally friendly easy to handle two compound cold casting material and a Hellstern Ring Connector.

These joints are easy and quick to assemble, resistant to breaks/cracks due to the elasticity of the compound, and mechanically robust due to the nature of the impact resistant polypropylene housing.

FEATURES

- Re-entrable, non toxic, two part compound
- No heating or naked flame required
- No cutting of main cable
- IPC for lower resistance



GURO MM5
Install Video

Cat No.	GURO Kit Size	No. of Cores	Main Conductor Size (mm ²)	Tap Off Conductor Size (mm ²)
GURO50/70KIT			50-70	
GURO70/150KIT	MM5	4	70-150	6-70
GURO150/185KIT			150-185	
GUROMM7/240		4	240	
GUROMM7/3C/95MM	MM7	3	95	6-70
GUROMM7/3C/185MMKIT			185	
GURO70-150/4-120KIT		4	70-150	4-120



CRSM SINGLE PHASE BRANCH JOINTS

APPLICATIONS

- Single phase branch joints for low voltage plastic cables
- DSWS Wrap-around technology with thermo-sensitive paint as visual guide
- Range taking USB Mechanical connector (-M kits only)
- Suitable for direct burial
- Branch off clip BOCL (-M & MD kits only) provides greater reliability of seal between two cables
- Temperature range -40°C to 120°C



WITH MECHANICAL CONNECTOR

Cat No.	Conductor Size Main (mm ²)		Conductor Size Tap (mm ²)
	Single Tail	Double Tail	
CRSM-CT1-M	CRSM-CT1-MD	25-95	16-35
CRSM-CT2-M	CRSM-CT2-MD	50-185	16-35
CRSM-CT3-M	CRSM-CT3-MD	185-300	16-35

WITHOUT CONNECTOR

Cat No.	Conductor Size - Main (mm ²)	Conductor Size - Tap (mm ²)	Connector Length (mm)
CRSM-CT-1-150	16-150	1.5-35	50
CRSM-CT-50-300		35-120	100
CRSM-CT-50-500	50-500	120-185	150





SUBMERSIBLE CONNECTORS FOR UNDERGROUND RETICULATION

The GelPort connection system represents a revolutionary product for secondary connectors. Strip the cable and push it into the gel-filled cable port. The cable is encapsulated in PowerGel and instantly sealed.



FEATURES

- Qualified to ANSI C119.1
- Hydrophobic PowerGel-filled cable entry ports provide a reliable cable seal in harsh environments
- Provides an excellent moisture seal over a wide range of operating temperatures (-40°C to 95°C)
- Rugged, impact-resistant housing stands up to rough installations
- Clear view back allows for easy positive

visual indication of wire position in connector

- Simple Allen key installation

BENEFITS

- Quick and easy installation
- Clean re-entry into electrical connection
- Unlimited shelf life when stored in normal conditions
- No loose parts due to one piece housing



Cat No.	Back Cover Colour	Number of Cable Ports	Cable Size (mm ²)	Dimensions (mm)		
				L	W	H
5-1899241-7		3	2×16 – 150, 1×16 – 240	117		
5-1899241-8		4	2×16 – 150, 2×16 – 240	149		
5-1899241-9	CLEAR	5	2×16 – 150, 3×16 – 240	180	97	89
6-1899241-0		6	2×16 – 150, 4×16 – 240	212		
6-1899241-1		8	2×16 – 150, 6×16 – 240	276		
7-1201146-7	BLACK	4	4×6 – 150	149	97	89
GPRT-300-3P-OR	CLEAR	3	2×185 – 300, 1×16 – 185	128	90	105

INSULATION PIERCING CONNECTORS

INSULATION PIERCING TECHNOLOGY

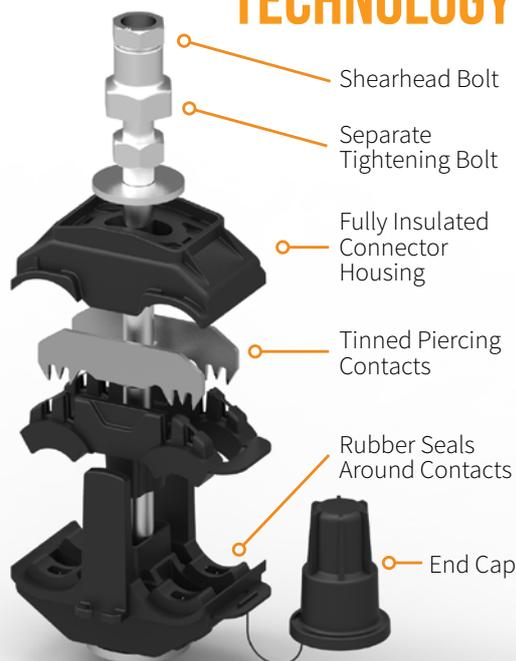

All our connectors are designed and tested to fit the majority of cable types made in accordance with the European Standard HD 626, regardless if cables are insulated with XLPE, PE or PVC. These products are tested according to national specifications such as NFC, VDE, BS, ESI and where possible in accordance to CENELEC EN 50483-4.

PRODUCT FEATURES

- Shearhead bolts ensure correct connection pressure everytime
- Range taking capabilities reduce the inventory requirements
- Connectors accept both Al and Cu cable (unless specified)
- Completely seals around contact points for watertight connection
- By not stripping the cable, contact teeth can make contact with cable before oxidation takes place
- All connectors come with contact grease

SAFETY FEATURES

- Safe to install on live circuits (when manufacturers guidelines are adhered to)
- Tightening bolt separate to piercing contacts remains permanently de-energised
- Cable doesn't need to be stripped, protecting workers from exposed live cables
- Fully insulated housing for worker safety



All Specials and Products featured in TRANSNET JUICE are available from all good electrical wholesalers.



STAINLESS STEEL FLOOR OUTLET BOXES



FB145SSF2PS65

Flush Steel Lid Outlet Box
Power & Shallow Body

POWDER COATED ZINC ANNEALED
STEEL BODY

STAINLESS STEEL LID & FRAME

DOUBLE CABLE EXIT FLAP

25MM KNOCKOUTS PROVIDED FOR
EASY CONDUIT ENTRY

TWO AUTO SWITCHED POWER
OUTLETS SUPPLIED

**ONLY
65MM
DEEP!**

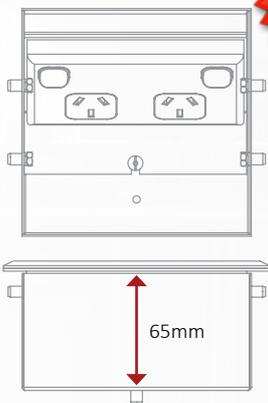

\$229
+GST

Carcass dimensions WxLxH 125x125x65mm
(71mm H including lid), 145x145mm lid



FB145SSF2P3D

Flush Steel Lid Outlet Box
Power & Data Provision

POWDER COATED ZINC ANNEALED
STEEL BODY

STAINLESS STEEL LID & FRAME

DOUBLE CABLE EXIT FLAP

25MM KNOCKOUTS PROVIDED FOR
EASY CONDUIT ENTRY

TWO AUTO SWITCHED POWER
OUTLETS SUPPLIED

PROVISION FOR THREE CAT5 OR
CAT6 DATA PORTS

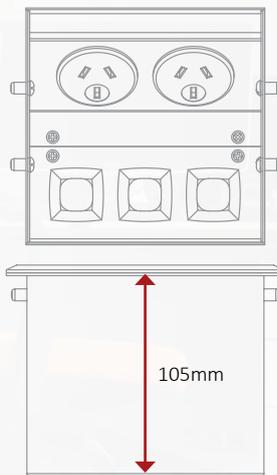

\$309
+GST

Carcass dimensions WxLxH 125x125x105mm
(110mm H including lid), 145x145mm lid

**.cable.
away**

Cableaway's floor outlet boxes are an ideal way to supply power to open floors of a commercial office building or residential area. With auto-switched outlets and data options they offer flexibility and convenience now and in the future. For other size and finishing options please contact us.

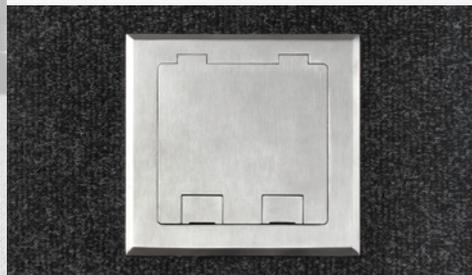
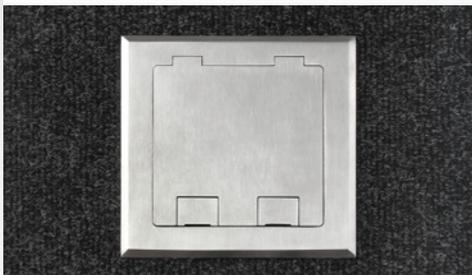



EVERYTHING YOUR APPRENTICE NEEDS!

TRANSNET APPRENTICE KIT

MD1060	LED Continuity Tester
MD106	Non-Contact Voltage Stick
211202	Linesman Pliers 200mm
101918	Screwdriver 125x5.5mm Slot
101920	Screwdriver 150x6.5mm Slot
101942	Screwdriver 80x PH1
101944	Screwdriver 100x PH2
102554	Screwdriver 100x Square
EKPZ	Kneepads
E4000	Clear Safety Glasses
E4004	Bronze Safety Glasses
E-MAX33	Foldable Earmuffs
13-4HFR	Work Gloves
TNCAP	Camo Cap
BEANIE	Beanie
TOOLBOX	Apprentice Toolbox

TNAPPKIT \$369.00 + GST



METREL MD9030 + MD9226 COMBO DEAL

The MD9030 has been designed for use in the lab as well as harsh industrial maintenance and repair. Its TRMS functionality suits many applications while the bright backlit screen is ideal for working in dark areas.

KEY FEATURES

- Accurate readings on sinusoidal and non-sinusoidal signals
- Measures temp up to 300 °C and 572 °F
- Frequency measurement up to 1 MHz
- Incorrect lead connection alert
- Auto-ranging
- Relative zero
- Data hold & MAX hold
- CAT IV/300V, CAT III/600V & CAT II/1000 V overvoltage protection

- 3-3/4 digits, 4000 count backlit LCD display

MEASURING FUNCTIONS

- TRMS AC, DC voltage & current measurements
- Capacitance, resistance, frequency, & temperature measurements
- Diode test
- Continuity test (acoustic signalling)



MD9030 TRMS DIGITAL MULTIMETER

MD9226 AC/DC 600A TRMS CURRENT CLAMP

The MD9226 has a wide range of extra features, including peak value, data and MAX hold functions, auto power off, auto-ranging and a relative zero function.

KEY FEATURES

- Auto-ranging
- Automatic, non-contact detection of electromagnetic fields to locate and trace live conductors
- Data hold function
- MIN/MAX/AVG function
- Peak value
- Relative zero
- 35mm jaw opening
- CAT IV / 300 V, CAT III / 600 V overvoltage categories
- LCD backlit display, 3-5/6 digit, 6000 count

MEASURING FUNCTIONS

- DC and TRMS AC voltage up to 600 V, current measurement up to 600 A
- Resistance, frequency & capacitance measurements
- Acoustic continuity test
- Diode test



TNMDPROMO \$579.00 + GST

All Specials and Products featured in TRANSNET JUICE are available from all good electrical wholesalers.

DRIVE SAFELY THIS MONTH

Safety Products for Vehicles



Auckland

78 Cryers Road
East Tamaki
Auckland
NEW ZEALAND
Ph 0800 442 182
Fax 0800 442 183
PO Box 39 383
Howick, Auckland

Wellington

10 Petone Ave
Petone
Wellington
NEW ZEALAND
Ph 04 576 2530
Fax 04 576 0040
PO Box 39 383
Howick, Auckland
NEW ZEALAND
sales@transnet.co.nz

TransNet Tonga

Nuku'alofa
Lakalakaimonu Multi Utility
Complex
Taufa'ahau Road
Poutaha
Nuku'alofa
TONGA
Ph +67 627 939
Fax +67 627 976
PO Box 2932
Nuku'alofa
TONGA
transnet@kalianet.to

FIRE EXTINGUISHERS

ABE POWDER TYPE PORTABLE

FEATURES

- High quality thick powder coating with increased UV resistance
- Supplied with vehicle bracket
- AS/NZS 1841.5 Approved
- Special hose hook to secure the hose to the side of the extinguisher body

Cat No.	Size	Price
G1HABE	1.0KG	\$40.49 +GST
G1.5ABESVB	1.5KG	\$55.81 +GST



Vehicle Bracket

VEHICLE FIRST AID KITS

FOR WORK WITH NO SPECIAL RISK

BOTH KITS CONTAIN:

- 1x First Aid Dressing Medium
- 1x First Aid Dressing Large
- 2x Sterile Eye Pad
- 1x Forceps
- 4x Antiseptic Wipes
- 3x Sodium Chloride Solution (Saline) 30ml Ampules
- 1x Resuscitation Face Shield
- 1x Clean-Up Bag
- 1x First Aid Tips Sheet
- 2x Triangular Bandage
- 1x HEP B / AIDS Warning Label
- 1x Pencil
- 1x Minor Accident Recording Form
- 1x Soft Carry Bag with Handle

FAK010N1S ALSO HAS:

- 1 x Sterile Non-Woven Swabs
- 2 x Safety Pins
- 1 x Economy Scissors
- 1 x Gauze Elastic Bandage 5cm
- 10 x Fabric Plasters
- 1 x Microporous Paper Tape 1.25cm
- 2 x Non-Adherent Pad 7.5x10cm
- 2 x Examination Gloves (Pair)

FAK015 ALSO HAS:

- 2 x Sterile Non-woven Swabs
- 1 x Wound Dressing No 15
- 10 x Safety Pins
- 1 x Utility Power Shears
- 2 x Crepe Bandage 5cm
- 3 x Combine Dressing 10x10cm
- 3 x Non-Adherent Pad 7.5x10cm
- 1 x Combine Dressing 20x20cm
- 1 x Plastic Tape 2.5cm Roll

Cat No.	Price
FAK010N1S	\$28.59 +GST
FAK015	\$43.56 +GST

FAK010N1S



FAK015



- 50 x Fabric Plasters (Wide)
- 4 x Examination Gloves (Pair)

TransNet NZ Ltd has made every reasonable effort to ensure the accuracy of this information and it is to the best of our knowledge correct and reliable. Under no circumstances does this constitute an assurance of any particular quality or performance and users should independently evaluate the suitability of products for their desired application. All information in this publication including pricing, drawings, illustrations, images and graphic designs are reflections of our current understanding. TransNet NZ Ltd reserves the right to make any adjustment to this information at any time. Our liability for the products outlined in this publication is set forth in our standard terms and conditions of trade. In case of any potential ambiguities or questions, please contact us for clarification.

